

**Cleco®**



# Productivity Is #1

The New Cleco D Series Pulse Tools

**COOPER** PowerTools

# The New Cleco Pulse

Introducing the new Cleco D Series pulse tool family which combines our legendary durability with our customer's increasing demands for productivity.

Industry first motor design and revolutionary preventative maintenance distance the new D Series from the competition. With outstanding ergonomics, you'll never want to put this tool down.

D Series redefines productivity by performing the job faster and staying on the job longer.



## **3X Increase Between Oil Changes.**

- Adjustable pulse chamber volume
- Tool achieves full torque after preventative maintenance
- No special tools needed

*The average tool is out of service almost 20 minutes for maintenance of hydraulic impulse unit.*

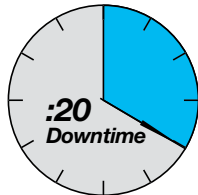

Average Tool

*With Cleco's patented design, maintenance time is only 2 minutes!*



New Cleco D Series



*The new D Series, shown actual size, is considerably smaller and lighter than the old 55PTH ghosted in the background.*

## **3-Chamber Air Motor.**

- Increased motor torque, lowers cycle time
- Usable high-end speed minimizes rundown time
- Unique design reduces blade wear

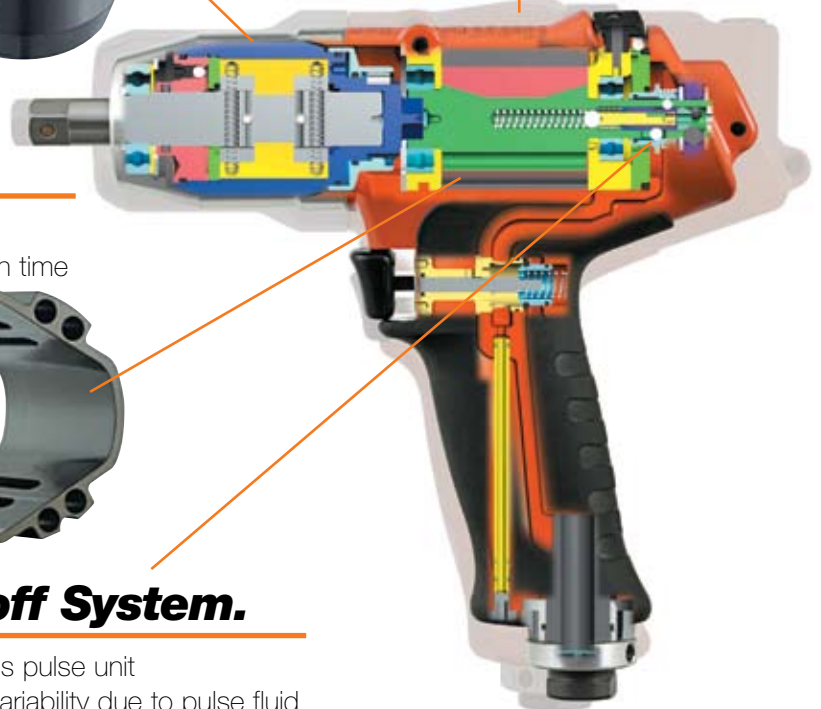

## **Inertial Shut-off System.**

- Onboard shut-off simplifies pulse unit
- Inertial shut-off removes variability due to pulse fluid

# e Tools = Productivity



## Easy Set-Up

- Insert 2mm hex into rear port of tool
- Positive stops in both directions to prevent loss and/or damage
- No confusion on which screw to adjust



## Ships Ready For Error Proofing

- Works with existing TVP torque verifier
- Located near air inlet to maximize ergonomics



Standard air signal indicating tool shutoff for use with Cleco TVP Error Proofing System.

**Cleco**<sup>®</sup>

# Cleco D Series Specifications



Model Number	Drive Type	Torque Range		Free Speed	Weight		Working CFM	Recommended Hose Size
		Ft. -Lbs.	Nm	RPM	lbs.	kg		
11PTHD65Q	1/4" QC	4.4-8.1	6-11	6500	1.87	0.85	12.3	3/8"
11PTHD652	1/4" Sq.Dr.	4.4-8.1	6-11	6500	1.81	0.82	12.3	3/8"
11PTHD653	3/8" Sq.Dr.	4.4-8.1	6-11	6500	1.83	0.83	12.3	3/8"
20PTHD75Q	1/4" QC	7.3-14.7	10-20	7500	1.92	0.87	12.3	3/8"
20PTHD753	3/8" Sq.Dr.	7.3-14.7	10-20	7500	1.90	0.86	12.3	3/8"
35PTHD65Q	1/4" QC	14.7-25.8	20-35	6500	2.2	1.0	16	3/8"
35PTHD653	3/8" Sq.Dr.	14.7-25.8	20-35	6500	2.2	1.0	16	3/8"
55PTHD603	3/8" Sq.Dr.	22.1-40.5	30-55	6000	2.4	1.1	19	3/8"
80PTHD60Q	7/16" QC	36.9-59	50-80	6000	3.2	1.45	19	3/8"
80PTHD604	1/2" Sq.Dr.	36.9-59	50-80	6000	3.1	1.4	19	3/8"
110PTHD55Q	7/16" QC	55.3-81.1	75-110	5500	3.75	1.7	30	1/2"
120PTHD554	1/2" Sq.Dr.	55.3-88.5	75-120	5500	3.75	1.7	30	1/2"

### General:

Tools rated at 6.0 bar (87 PSI)  
Tools rated at < 80 dBA

### Standard Equipment:

Suspension bail; torque adjustment screwdriver; Torque error proofing signal port.

## Accessories



### Cleco TVP-100 Torque Verifier

- Verifies fastener installation with **OK/NOK** audio and visual indicators

Model Number		Language
115VAC	230VAC	
TVP-110-15-U	TVP-110-30-U	English
TVP-110-15-D	TVP-110-30-D	German
TVP-110-15-S	TVP-110-30-S	Spanish
TVP-110-15-P	TVP-110-30-P	Portuguese

All model numbers include power cable, air signal transducer, and 25 foot cable to connect TVP to air signal transducer.

### Torque Signal Kit

Part No.	Tool Used On
934918	PTH series pulse tools ("C" & "D" vintage)

### 7/16" Quick Change Chuck

935472



- For 55 Nm tools
- Pilot on output shaft to minimize runout



### Rubber Tool Stand

Part No.	Tool Series
931041	D Series 7PTH - 120PTH

**Cooper Power Tools**  
P.O. Box 1410  
Lexington, SC 29071-1410  
USA  
Phone: 800-845-5629  
803-359-1200  
Fax: 803-359-0822

**Cooper Power Tools**  
4121 North Atlantic Blvd.  
Auburn Hills, MI 48326  
USA  
Phone: (248) 391-3700  
Fax: (248) 391-6295

**Cooper Power Tools**  
5925 McLaughlin Road  
Mississauga, Ontario  
Canada L5R 1B8  
Phone: (905) 501-4785  
Fax: (905) 501-4786

**Cooper Power Tools de México S.A. de C.V.**  
Libramiento La Joya No. 1  
Bodega No. 2  
Esq. Politécnico  
Barrio San José  
Cuautitlán, Edo de México  
C.P. 54870

Phone: +52-55-5899-9510  
Fax: +52-55-5870-5012

**Cooper Tools Industrial Ltda.**  
Av. Liberdade, 4055  
Zona Industrial - Iporanga  
18087-170 Sorocaba, SP  
Brazil  
Tel: +55-15-3238-3929  
Fax: +55-15-228-3260

**Cooper Power Tools SAS**  
Zone industrielle - B.P. 28  
77831 Ozoir-la-Ferrière Cedex  
France  
Téléphone: +33-1-6443-2200  
Téléfax: +33-1-6440-1717

**Cooper Power Tools GmbH & Co. OHG**  
Postfach 30  
D-73461 Westhausen  
Germany  
Phone: +49 (0) 73 63/ 81-0  
Fax: +49 (0) 73 63/ 81-222  
E-Mail: sales-de@cooperindustries.com

**Cooper Tools Hungária Kft.**  
Berkenyefa sor 7  
H-9027 Győr  
Hungary  
Tel: +36-96-505 300  
Fax: +36-96-505 301

**Cooper (China) Co., Ltd.**  
955 Sheng Li Road,  
Heqing Pudong, Shanghai  
China 201201  
Tel: +86-21-28994176  
+86-21-28994177  
Fax: +86-21-51118446

[www.cooperpowertools.com](http://www.cooperpowertools.com)

**Cooper Industries, Ltd.**  
600 Travis, Ste. 5800  
Houston, TX 77002-1001  
P: 713-209-8400  
[www.cooperindustries.com](http://www.cooperindustries.com)

